

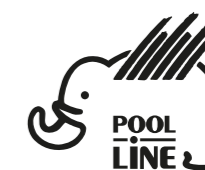

N	Q
1	1+1
2	1+1
3	4+4
4	2+2
5	12
6	8
7	1
8	1

N	BO0054 x2	Q
11	DIN6923 M6	32
12	DIN912 M6x20	32
13	DIN125 Ø6	32
BO0014 x 4		
14	DIN912 M6x20	8
15	DIN9021 Ø6	8

- E** Instrucciones de montaje Kit de fijación
- C** Instruccions de muntatge Kit de fixació
- GB** Assembly instructions Fixation Kit
- F** Instruction de montage Kit fixation
- D** Montageanleitung Stützfuß-Kit
- PT** Instruções de montagem Kit fixação
- I** Istruzioni di montaggio Kit di fissaggio
- PL** Instrukcja montażu Element mocujący
- CZ** Montážní návod Fixační kit
- HU** Szerelési Utasítás Rögzítő készlet
- RO** Instrucțiuni de montaj Kit de fixare
- HR** Detaljne upute Kit za montažu
- TU** Öncelikle montaj Montaj kiti



POOL-LINE ACCESORIOS, S.L.  
C. Esqueis, 19. P. I. Can Barri  
08415- Bigues i Riells. Barcelona (España)  
www.pool-line.net

Nº HOMOLOGACIÓN: **Eg** 26R-03.1042

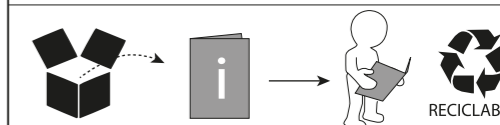

**121095**

Rv: 02/2024



Limpeza pre-instalación



Pre-installation cleaning

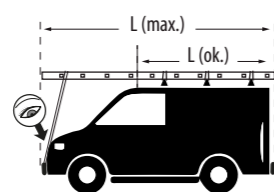

Revisar par de apriete



Check torque

**• FORD CONNECT II TRANSIT (2013-2022)**  
**• FORD CONNECT II TOURNEO (2013-2022)**

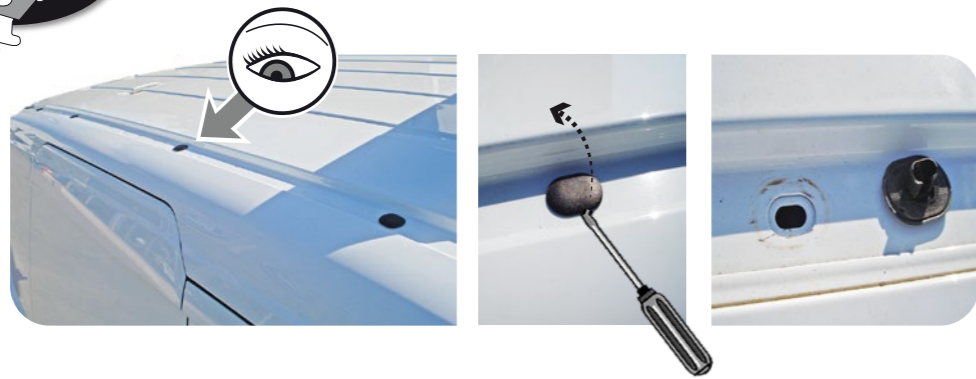

**\* ZONAS CON TECHO TAPIZADO / TAPIZADO ROOF ZONES**



**E** •Separar la goma del tapizado para acceder al interior del techo vehículo

**GB** •Separate the rubber upholstered to access the interior of the vehicle roof

**I** •Si separano gomma cornice per accedere all'interno del tetto del veicolo

**F** •Séparer le caoutchouc garniture pour accéder à l'intérieur du toit du véhicule

**D** •Trenne die Gummipolster das Innere des Fahrzeugdaches zugreifen

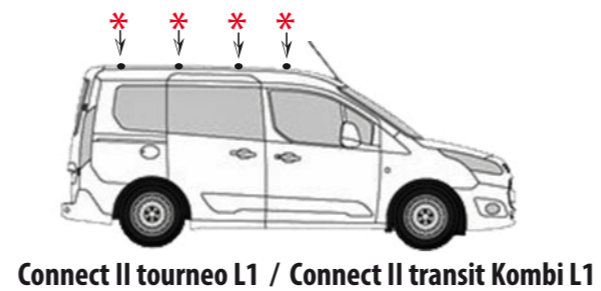

**Connect II tourneo L1 / Connect II transit Kombi L1**

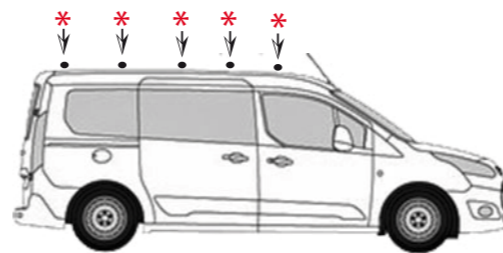

**Connect II tourneo L2 / Connect II transit Kombi L2**

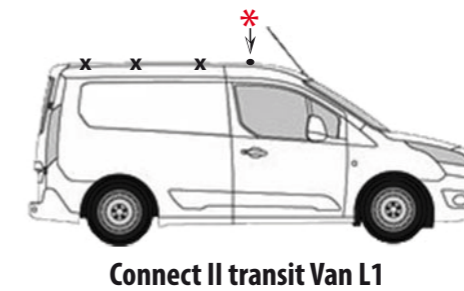

**Connect II transit Van L1**

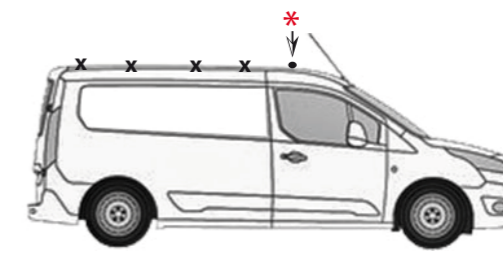

**Connect II transit Van L2**

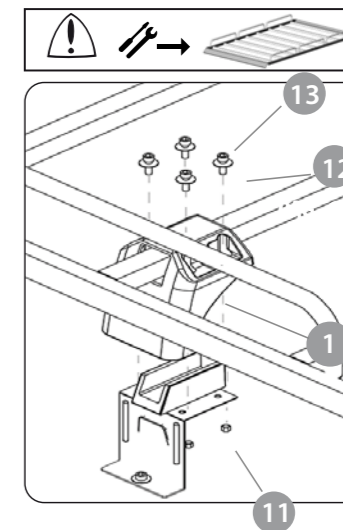
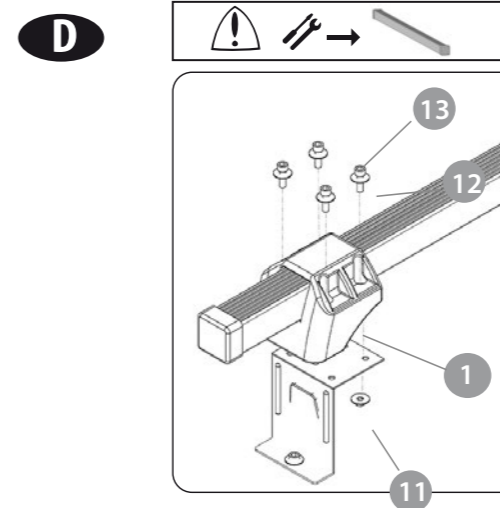
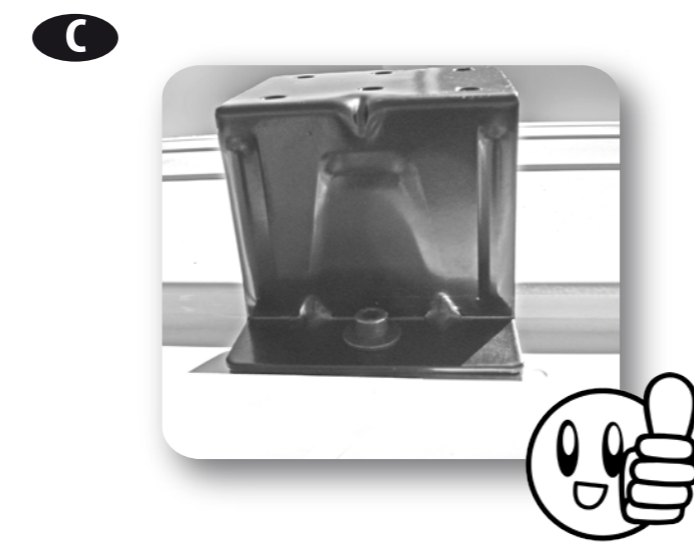
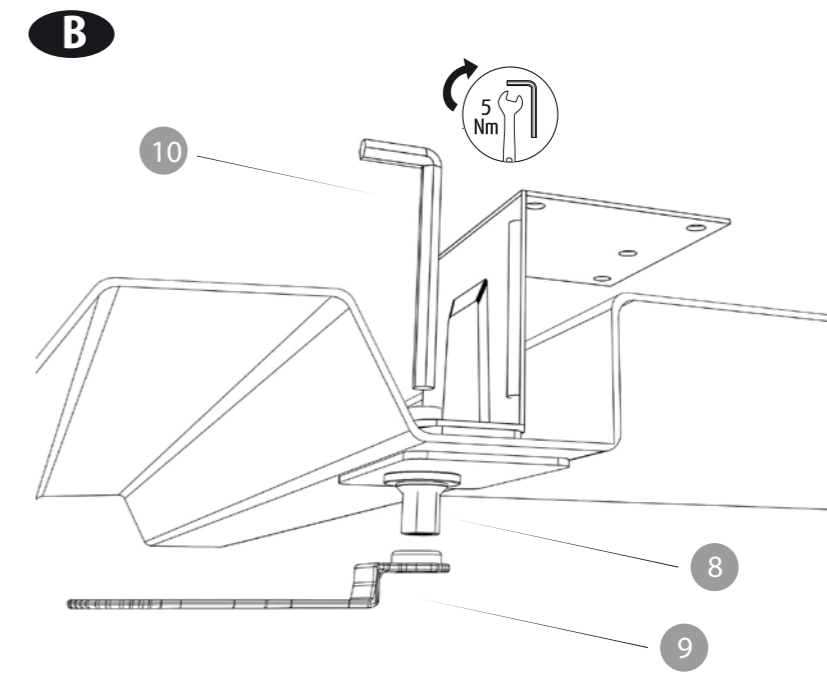
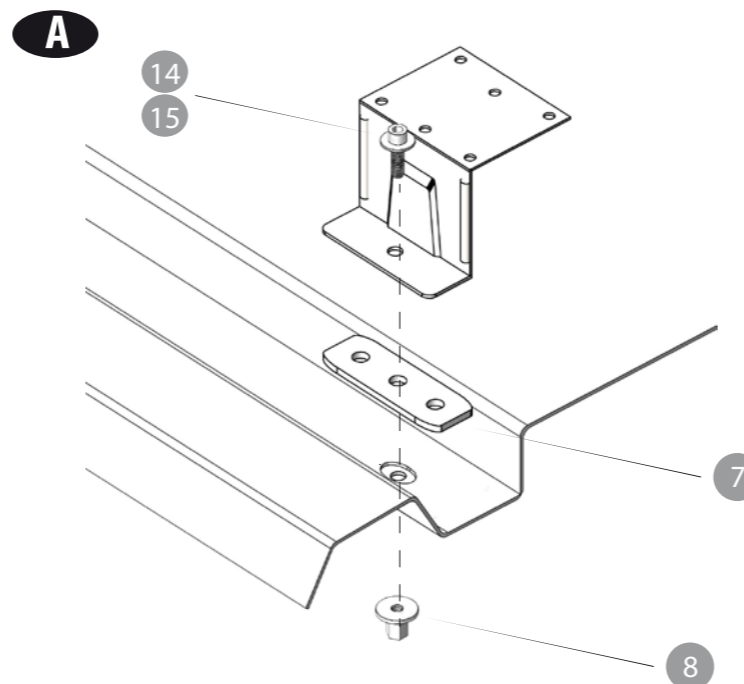



- FORD CONNECT II TRANSIT L1-H1 (2013-2022)
- FORD CONNECT II TOURNEO L1-H1 (2013-2022)

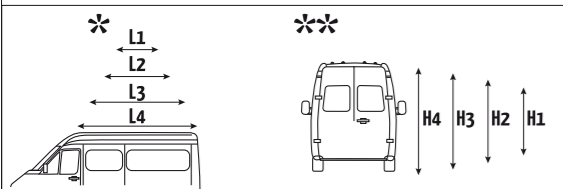
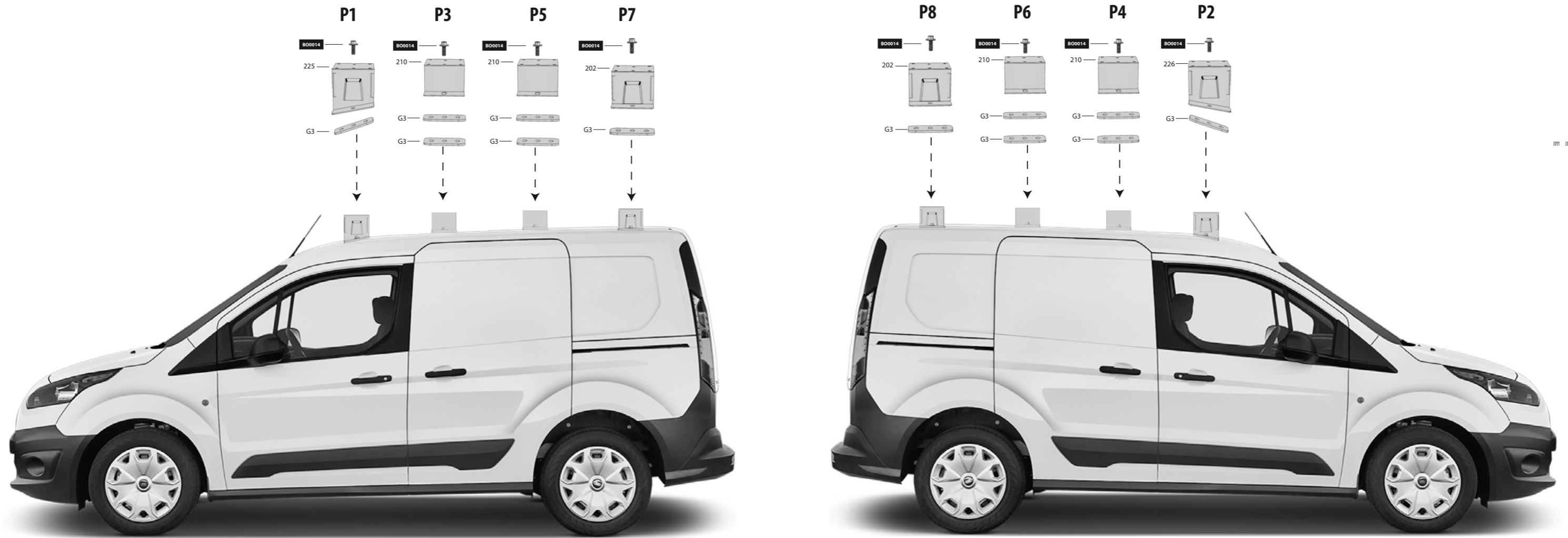

	L*	H**	↻	↙	P1	P2	P3	P4	P5	P6	P7	P8
<b>FORD</b>												
Connect II Tourneo	L1	H1	13 - 22	B00014	225+1A+1G3	226+2A+1G3	210+1B+2G3*	210+1B+2G3*	210+1B+2G3*	210+1B+2G3*	202+1C+1G3	202+1C+1G3
Connect II Transit Van	L1	H1	13 - 22	B00014	225+1A+1G3	226+2A+1G3	210+1B+2G3*	210+1B+2G3*	210+1B+2G3*	210+1B+2G3*	202+1C+1G3	202+1C+1G3
Connect II Transit Kombi	L1	H1	13 - 22	B00014	225+1A+1G3	226+2A+1G3	210+1B+2G3*	210+1B+2G3*	210+1B+2G3*	210+1B+2G3*	202+1C+1G3	202+1C+1G3



• FORD CONNECT II TRANSIT L2-H1 (2013-2022)  
 • FORD CONNECT II TOURNEO L2-H1 (2013-2022)

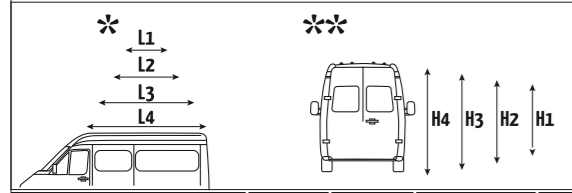
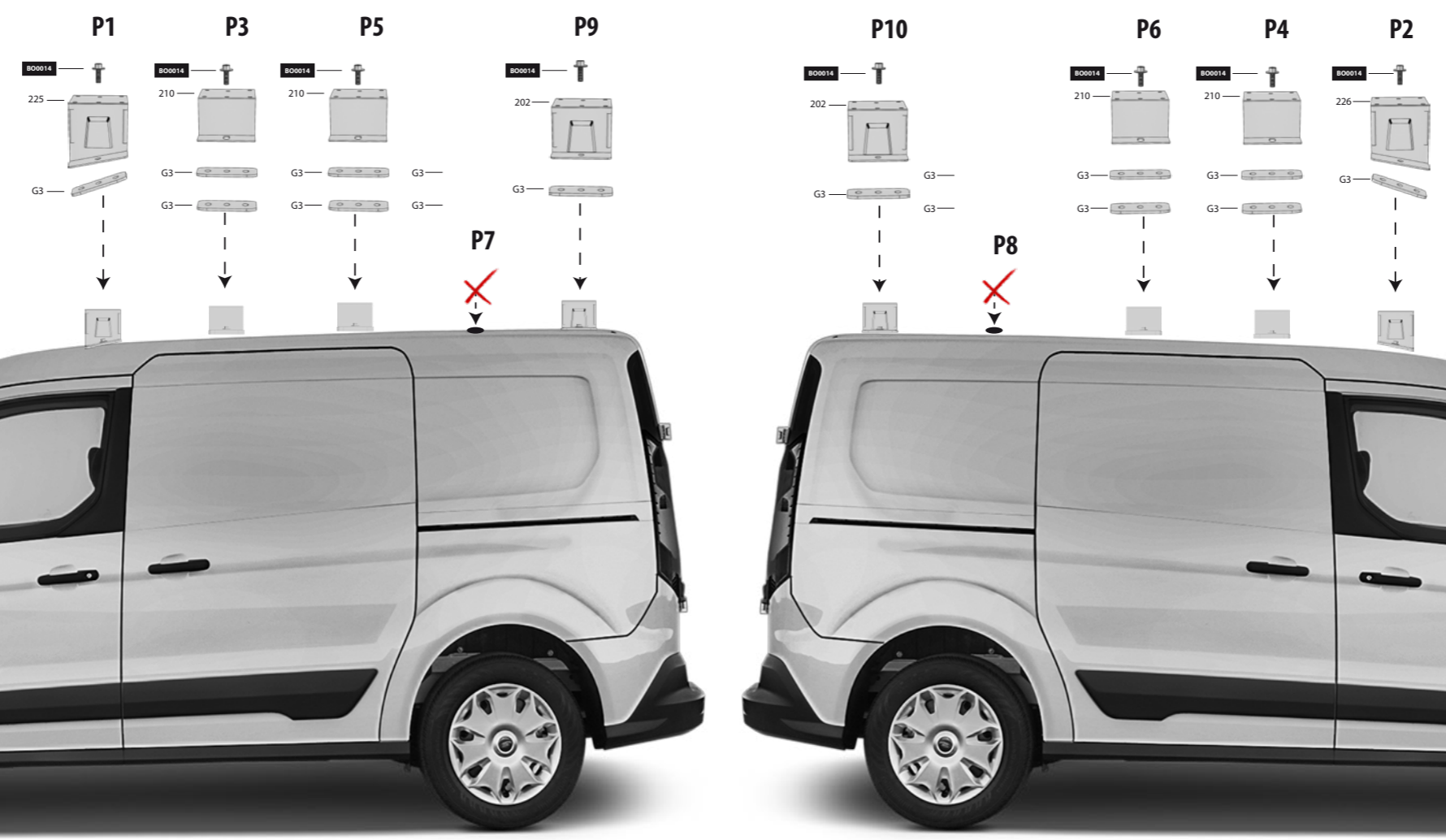

	L*	H**	⌚	⚙️	P1	P2	P3	P4	P5	P6	P7	P8	P9	P10
<b>FORD</b>														
Connect II Tourneo	L2	H1	13 - 22	B00014	225+1A+1G3	226+2A+1G3	210+1B+2G3*	210+1B+2G3*	210+1B+2G3*	210+1B+2G3*	✗	✗	202+1C+1G3	202+1C+1G3
Connect II Transit Van	L2	H1	13 - 22	B00014	225+1A+1G3	226+2A+1G3	210+1B+2G3*	210+1B+2G3*	210+1B+2G3*	210+1B+2G3*	✗	✗	202+1C+1G3	202+1C+1G3
Connect II Transit Kombi	L2	H1	13 - 22	B00014	225+1A+1G3	226+2A+1G3	210+1B+2G3*	210+1B+2G3*	210+1B+2G3*	210+1B+2G3*	✗	✗	202+1C+1G3	202+1C+1G3